

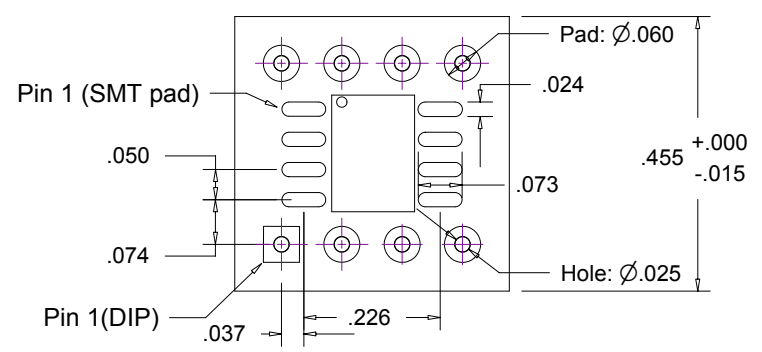

REVISIONS

ZONE	REV	DESCRIPTION	DATE	APPROVED
------	-----	-------------	------	----------



- Notes:
1. Exposed copper is solder plated.
 2. Copper thickness: 1oz.
 3. Soldermask applied to both sides.
 4. Tolerance of pad-to-pad centers: +/- 0.002"

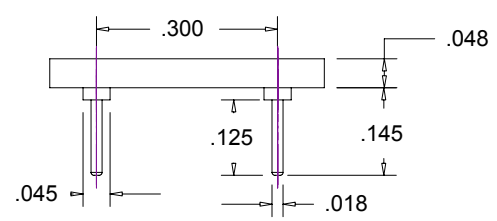
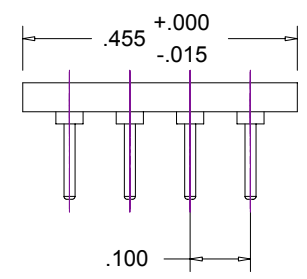

	DRAWN pmm	DATE 5/19/03	Cimarron Technology, Inc.		
	CHECKED				
	QA		SO8 to 8-pin DIP Adapter		
MFG		SIZE A			
	APPROVED		SCALE		SHEET

